

A size-selected metal nanocluster source for synchrotron radiation studies

Elisa Miniussi^(1,2), Alessandro Baraldi^(1,2), Friedrich Esch⁽³⁾ and Ueli Heiz⁽³⁾



(1) Physics Dept.-University of Trieste, Via Valerio 2, 34127 Trieste, Italy
(2) IOM-CNR Laboratorio TASC, Area Science Park, S.S. 14 Km 163.5, I-34149 Trieste
(3) Lehrstuhl für Physikalische Chemie, Technische Universität München, Lichtenbergstr. 4, 85748 Garching, Germany

e-mail: elisa.miniussi@elettra.trieste.it

In the last decade, transition metal nanoclusters have attracted an increasing interest in the field of surface science.

It is acknowledged that atomic aggregates in the nanometer size range, i.e. formed by dozens or hundreds of atoms, show remarkably different properties with respect to their bulk crystalline counterparts. Magnetic data storage, single molecule sensing and heterogeneous catalysis are among the technologically most relevant fields where supported nanoclusters are expected to have the strongest impact.

In this respect, nanoclusters deposited on solid surfaces display novel electronic and magnetic properties with size-dependent magnetic anisotropy, orbital and spin moment.

In addition, nanoclusters exhibit an enhanced catalytic efficiency compared to their bulk or surface counterparts.

When the particle size is reduced to few nanometres, two main challenges are posed: (a) how to generate, in a controllable and reproducible way, large-scale replicas of the individual building blocks on a suitable substrate; (b) determining and tuning the geometric and electronic structure of supported nanoclusters.

It is therefore easily understood that the capability to select the size and composition of metal clusters would open up the opportunity to tailor their properties, thus paving the way towards the creation of novel materials with advanced functionalities.

EXPERIMENTAL SETUP AND OPERATING PRINCIPLES

3) Travel through the octupole:

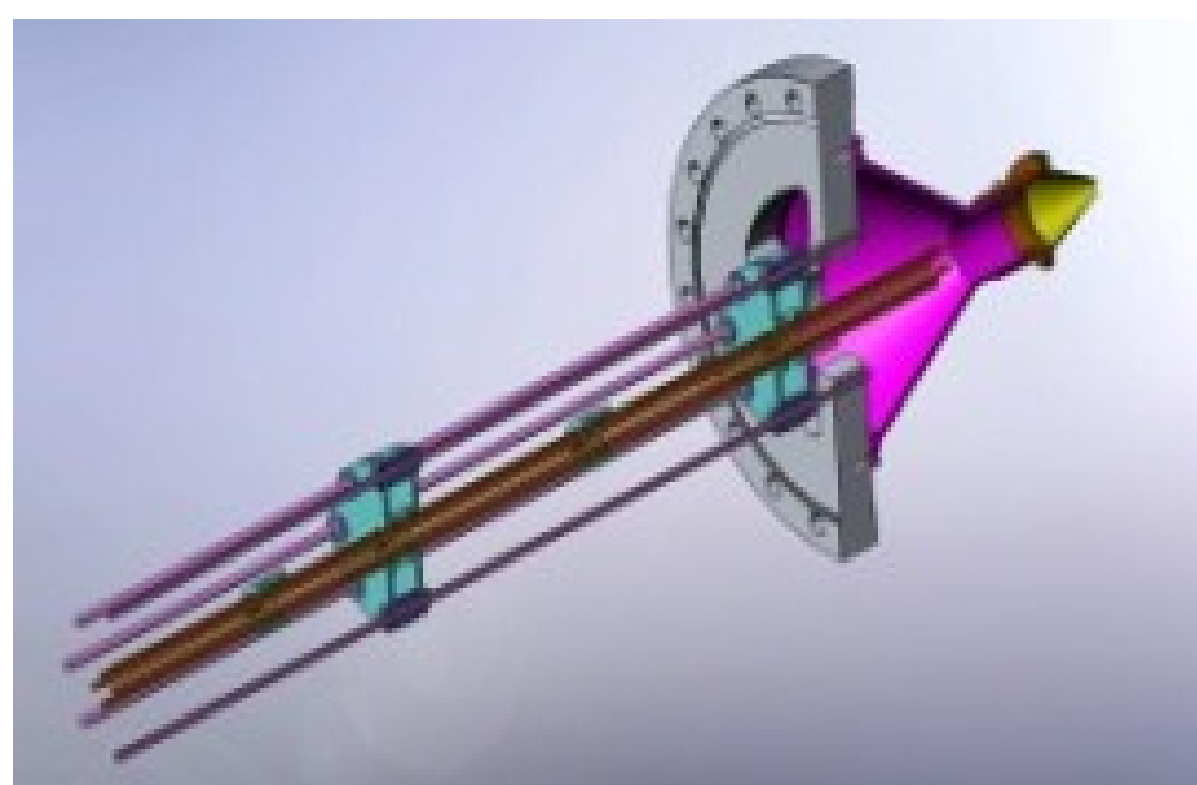

The octupole is used as an ion guide which focuses the clusters. It consists of eight stainless steel rods of equal diameter arranged in an equidistant circular arrangement. An electric field generated by the superposition of a DC and a RF signal (produced by a radio transceiver) focuses the ions towards the central axis. An external LC circuit (transducer) is used to superimpose the two signals and to apply the required potential to the rods. The frequency of the AC field should be tuned in order to achieve close-to-resonance conditions and thus maximize the ion transmission.

4) Ion optics:

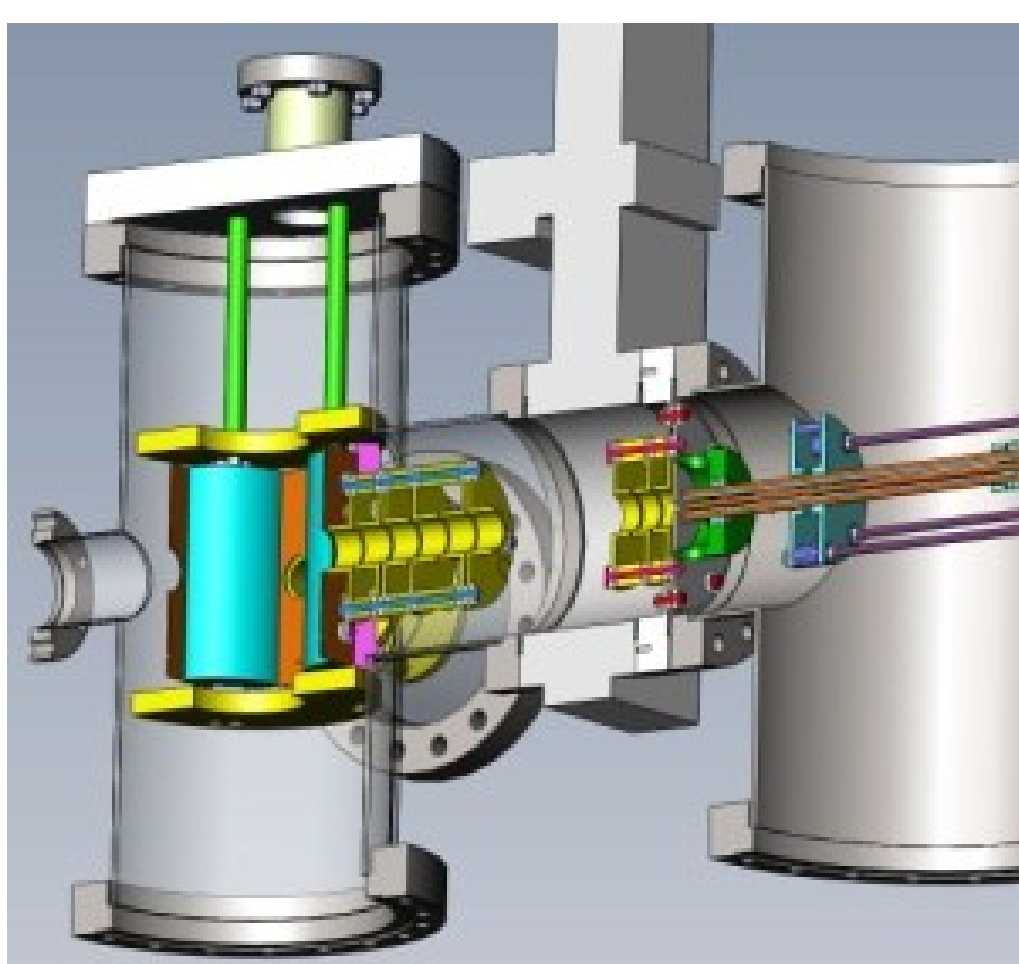

The ion optics includes stacks of biased electrostatic lenses which guide the cluster ions through the differentially pumped vacuum system in order to avoid losses and to increase transmission. The bender consists of four cylindrical rods which are biased to a tunable potential in such a way that the incoming ion beam is subjected to the Lorenz force $F=q(\mathbf{E}+\mathbf{v}\times\mathbf{B})$. The particles are thus deflected by 90° in order to separate the cations from the neutrals and the anions. The bender acts as a first mass filter by increasing the beam divergence, which is mainly determined by initial effects.

Our main targets:

- Investigation of the morphology, reactivity and electronic structure of size selected nanoclusters;
- Use of self-assembly on suitable substrates to study the organization of matter at the nanometer scale, in order to obtain high density arrays of nanoparticles periodically repeated over extended distances

Planned research strategy (following machine commissioning):

- Use of graphene as a substrate for the growth of self-organized superlattices of nanoclusters.
- TM atoms deposited on graphene grown on different substrates assemble into evenly spaced 2D cluster arrays.
- Graphene allows to stably anchor metal clusters, preventing sintering phenomena
- Use of microscopy and state of the art synchrotron radiation based spectroscopy techniques to characterize the systems
- Comparison between experimental results and state-of-the-art *ab initio* theoretical calculations

References:

- [1] U. Heiz, F. Vanolli, L. Trento, W.-D. Schneider, *Chemical reactivity of size-selected supported clusters: An experimental setup*, Rev. Sci. Instrum. **68** (1997) 1986
[2] A. N'Diaye, S. Bleikamp, P. J. Feibelman and Th. Michely, *Two Dimensional Ir-Cluster Lattices on Moire of Graphene with Ir(111)*, Phys. Rev. Lett. **97** (2006) 215501
[3] Z. Zhou, F. Gao and D.W. Goodman, *Deposition of metal clusters on single-layer graphene/Ru(0001): Factors that govern cluster growth*, Surf. Sci. Lett. **604** (2010) L31.

2) Supersonic beam expansion:

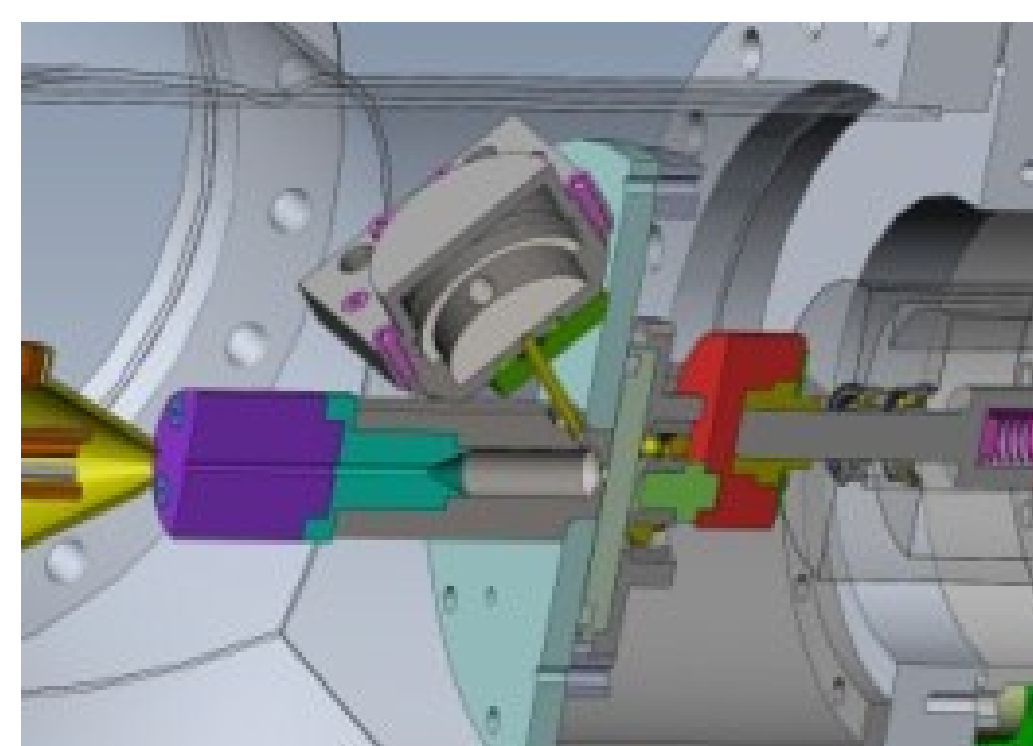

The hot plasma of metal ions is hauled to the next stage by a high pressure He jet. The piezoelectric valve used for buffer gas inlet is pulsed at the same frequency of the laser, using the trigger of the flash lamp as master trigger. (The time delay between the pulses should be adjusted in order to maximize the cluster current). The ion beam undergoes a supersonic expansion inside the nozzle and is subsequently confined by a skimmer. The latter collimates the beam, collects most of the gas from the source chamber and prevents shock waves from dispersing the beam

1) Ablation of a metal target

The second harmonic ($\lambda=532$ nm) of a high frequency pulsed Nd:YAG laser source is used to ablate the surface of a metal target and to produce a hot metal ion plasma. To prevent the laser beam from drilling holes and grooves, the sample is made to rotate through a motor driven hypocycloidal gear assembly. In this way, however, the laser spot draws a series of hypocycloids on the surface, which eventually leads to sample outwearing over time.

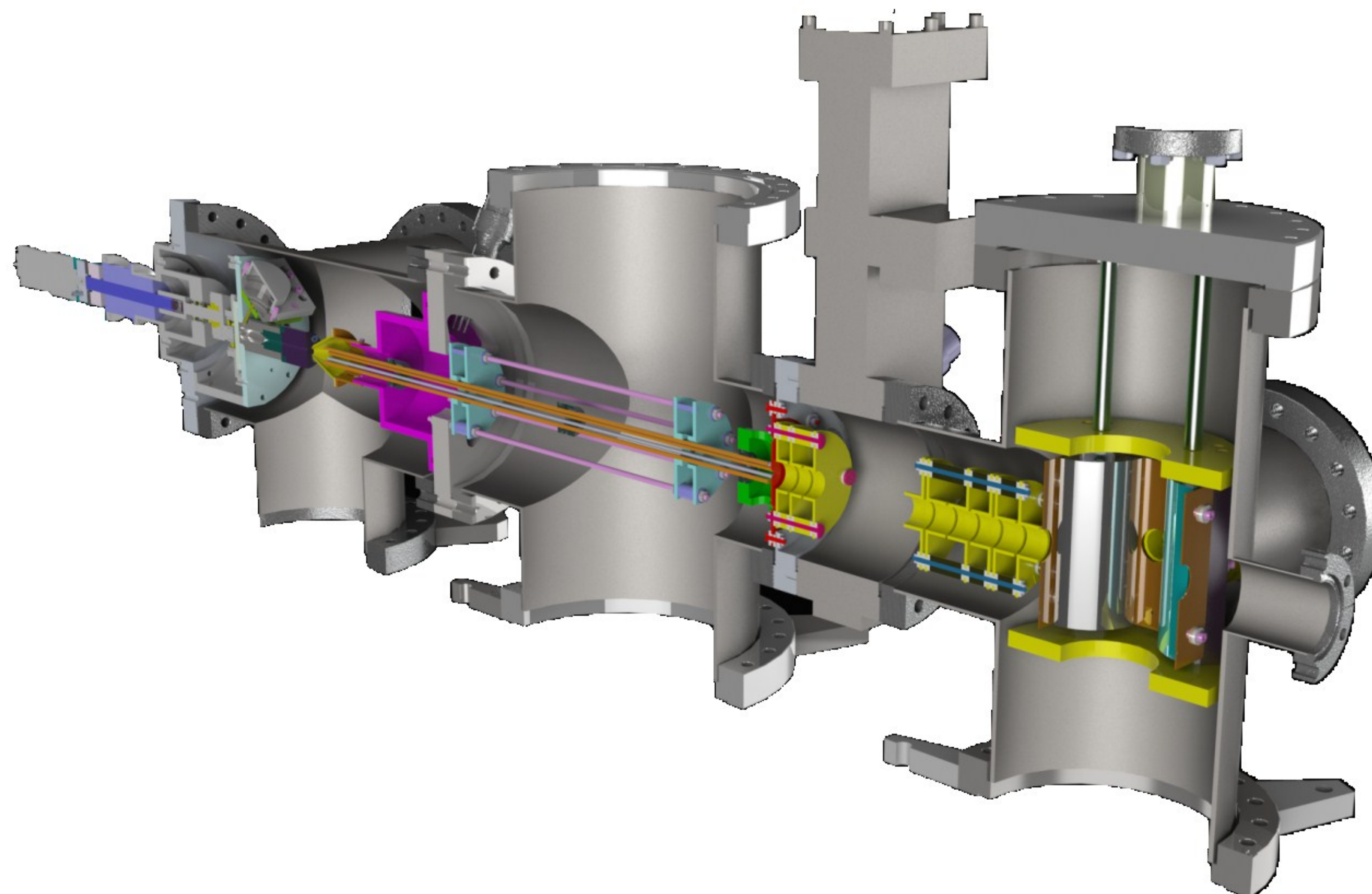

6) Deposition on the substrate:

In the final stage, the ion beam coming out of the QMS is refocused by a series of optical elements, and subsequently deposited on the sample. Soft landing conditions are required in order to avoid cluster breakup or pinning to the substrate. A narrow energy distribution of the clusters is an important property to attain soft landing conditions. If necessary, a retarding bias can be applied to the sample to decelerate the ion beam.

5) Mass selection:

Mass selection is performed by a quadrupole mass spectrometer (QMS), which separates the ions according to their q/m ratio by means of an RF field superimposed to a DC signal. The potential applied to the rods can thus be expressed as: $U+V \cos(\omega t)$ (ω is the frequency of the AC field). Transmission conditions are expressed by Mathieu's equations and can be summarized in the Mathieu stability diagram. The resolution of the QMS has to be adjusted according to the mass of the selected particles: larger clusters typically require a higher resolution.



Main topics of investigation:

- Role of the substrate on the nanoscale periodicity of the superlattices;
- Thermal stability of self-assembled superlattices;
- Correlation between geometric structure of the nanoclusters and electronic properties of the clusters/graphene interface;
- Dependence of doping effects and electron transfer capabilities on particle size, geometry and nanocluster arrangement.

- Role of superlattice properties (cluster size and periodicity, electronic structure) in dissociation, oxidation and reduction processes;
- Characterization and control of the magnetic properties of nanoclusters-graphene systems, in sight of possible applications in graphene-based electronic devices.

Experimental techniques:

- **STM**: temperature-induced nucleation of clusters and density-dependent statistical inhomogeneities;
- State-of-the-art **XPD** and **XANES** (using synchrotron radiation): structural analysis of size-selected nanoclusters;
- **ARPES** and high energy resolution **XPS**: investigation of the electronic structure of size-selected nanoclusters;
- **Time resolved XPS** or **FAST XPS** (using synchrotron radiation) to tackle surface reactions involving metal nanocluster by real time measurements.